

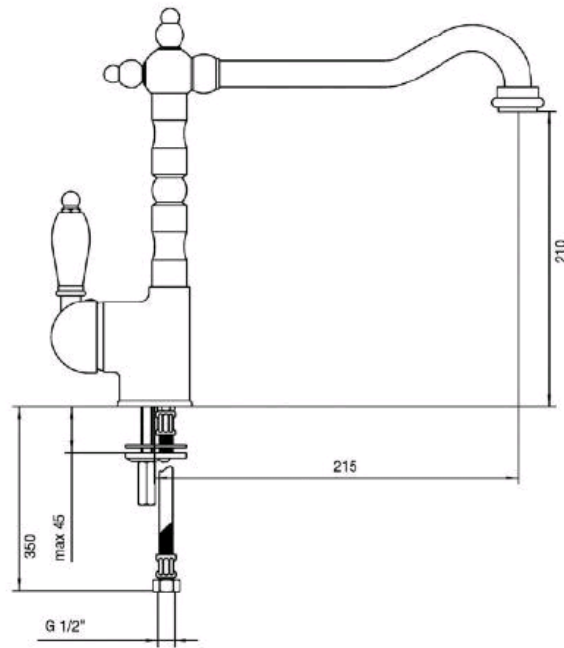

Bathroom
Kitchen
Laundry

ANTIQUA MIXER BRONZE



The single lever, swivel spout with aerator, Antiqua shows up its pure lines. Its objective, aesthetic taste making it unique and at the same time versatile and part of the kitchen.

Supplied With:

45mm Ceramic Disc

Hot and Cold Water Hoses.

Five year warranty.

3 STAR WELS rating , Water Flow Rating 9L/Min

Lic No 0061



Product Code: TAQSMAB

ANTIQUA MIXER BRONZE TWIN HANDLE



Classic Design Double Lever, Swivel Spout with Aerator.

Antiqua shows up its pure lines with its Classical & Versatile Design

Supplied With:

45mm ceramic Disc

Hot and Cold Water Hoses.

5 year warranty

3 STAR WELS Rating ,9L/Min Water Flow

Lic No 0061

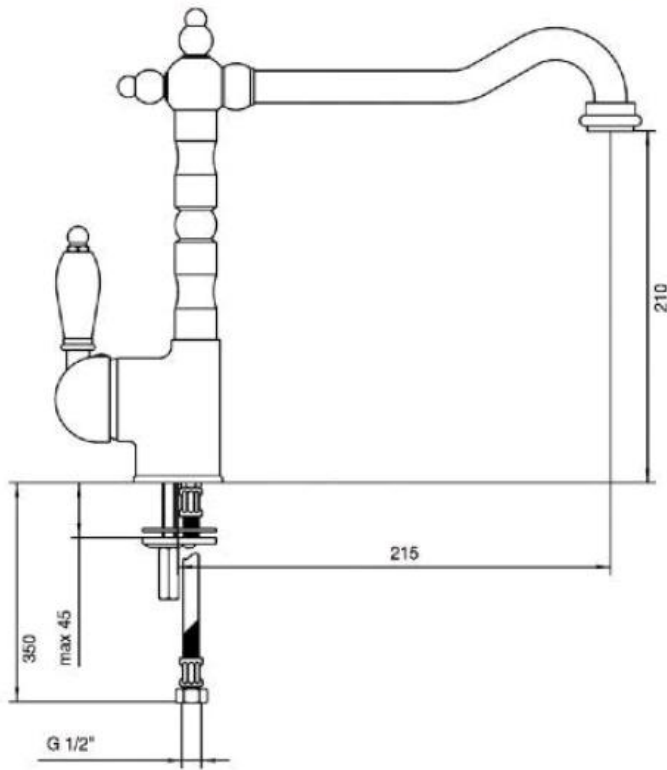

Product Code: TAQSMABTWIN

ANTIQUA MIXER CHROME



The single lever, swivel spout with aerator, Antiqua shows up its pure lines. Its objective, aesthetic taste making it unique and at the same time versatile and part of the kitchen.

Supplied With:

45mm Ceramic Disc

Hot and Cold Water Hoses

Five year warranty.

3 STAR WELS rating which means a usage of 9L/Min

Lic No 0061

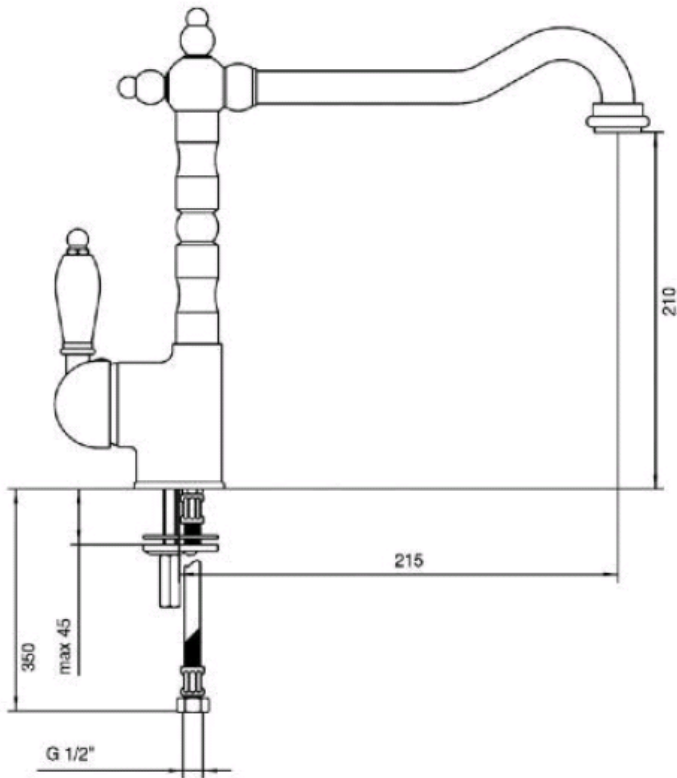

Product Code: TAQSMAC

ANTIQUA MIXER CHROME TWIN HANDLE



The double lever, swivel spout with aerator, Antiqua shows up its pure lines. Its objective, aesthetic taste making it unique and at the same time versatile and part of the kitchen.

Supplied With:

45mm Ceramic Disc

Hot and Cold Water Hoses.

Five year warranty.

3 STAR WELS rating ,which means a usage of 9L/Min

Lic No 0061

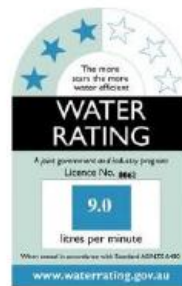
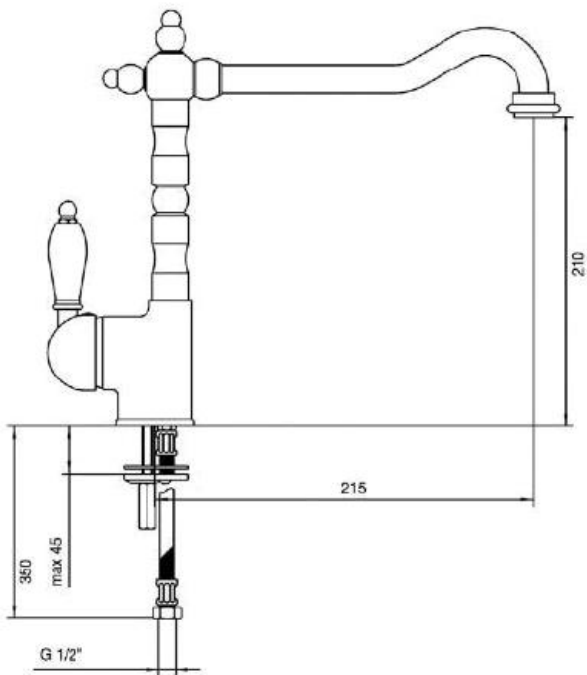

Product Code: TAQSMACTWIN

PLEASE NOTE:

ALL PRICES ON THIS BROCHURE & SINKWAREHOUSE WEBSITE SUBJECT TO CHANGE WITHOUT NOTICE

ALL PICTURES & DRAWINGS ON THIS BROCHURE ARE REPRESENTATIONAL ONLY, CHANGES IN THE PRODUCT MAY HAVE OCCURRED SINCE THE TIME OF PRINT

ALL STAINLESS STEEL PRODUCTS PICTURED IN THIS BROCHURE ARE 304 GRADE



**OSBORNE PARK SUPER STORE -
16 King Edward Road**

**Phone: (08) 9244 4486
Fax: (08) 9446 6877**

**Mandurah -
Unit 113, Fitzgerald Road
Greenfields
Phone: (08) 9583 3900
Fax: (08) 9583 3911**

**Caning Vale - Unit 2/165
Bannister Road**

**Phone: (08) 9456 2299
Fax: (08) 9456 3599**

**Midvale -
6 Elliott Street (Facing Gt
Eastern Hwy)
Phone: (08) 9274 8677
Fax: (08) 9274 8577**

**Myaree -
Unit 2/9 Carr Place**

**Phone: (08) 9330 1500
Fax: (08) 9317 3700**

www.sinkwarehouse.com.au